

# LISTA DE APLICACIONES - BUYERS GUIDE

## RB2275



Qty: 300

Weight: 1.825

O.E.M.	MAKE
7 736 762 8	FIAT
7 736 791 0	FIAT
7 736 836 8	FIAT

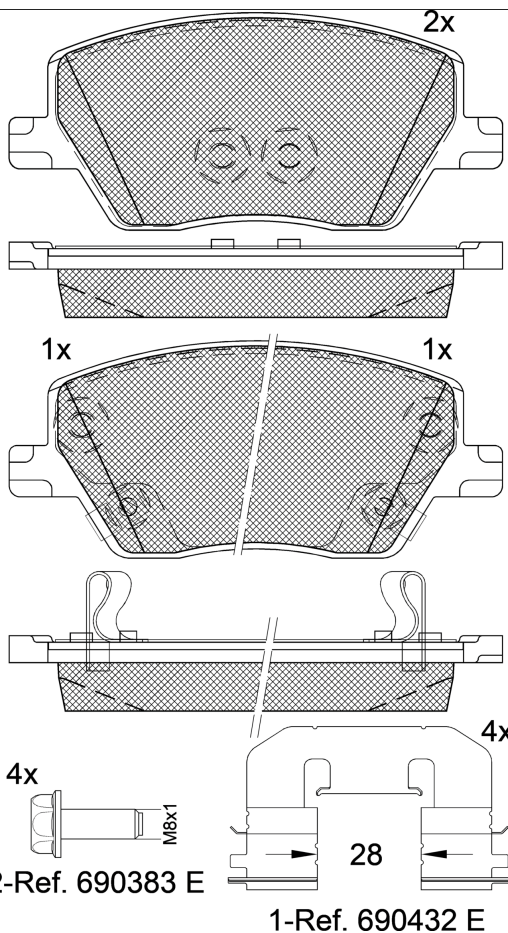

## RB2275

**E 9 90R-02A0111/4583**



Mando

133x58.6x19.2

**WVA**

22397

22398

22399

Sin Filas



Trac.	CC	Kw	CV
-------	----	----	----



Front / Rear

### DODGE

#### NEON III 08.16-

#### Sedán (Compact car-C Segment)

1.4	Gasolina	FWD	1368	71	97	08.16-	*
1.6 (EJM)	Gasolina	FWD	1598	82	112	08.16-	*

### FIAT

#### TIPO / EGEE (356\_, 357\_) 03.16-

#### [CAMBIADO]:Break (Compact car-C Segment)

1.0 (357WXN1A)	Gasolina	FWD	999	74	101	11.20-	*
1.4 (356WXA1B) (843 A1.000)	Gasolina	FWD	1368	70	95	03.16-10.20	*
1.4 (356WXF1B) (940 B7.000)	Gasolina	FWD	1368	88	120	03.16-10.20	*
1.6 (356WXE11) (552 68 036)	Gasolina	FWD	1598	81	110	07.16-10.20	*
1.5 T4 Hybrid	Gasol./el éc.	FWD	1469	96	131	03.22-	*
1.3 D (356WXH1A) (552 66 963)	Diesel	FWD	1248	70	95	03.16-	*
1.3 D (356WXH1A) (552 83 775)	Diesel	FWD	1248	70	95	03.16-	*
1.6 D (356WXG1B) (552 60 384)	Diesel	FWD	1598	88	120	03.16-10.20	*
1.6 D (356WXG1B) (552 80 444)	Diesel	FWD	1598	88	120	03.16-10.20	*
1.6 Multijet (357WXG1)	Diesel	FWD	1598	96	131	11.20-	*

#### TIPO / EGEE (356\_, 357\_) 03.16-

#### [CAMBIADO]:Fastback (Compact car-C Segment)

1.0 (357HXN1A)	Gasolina	FWD	999	74	101	11.20-	*
1.4 (356HXA1B, 357) (843 A1.000)	Gasolina	FWD	1368	70	95	03.16-	*
1.4 (356HXF1B) (940 B7.000)	Gasolina	FWD	1368	88	120	03.16-10.20	*
1.6 (356HXE11) (552 68 036)	Gasolina	FWD	1598	81	110	07.16-10.20	*
1.5 T4 Hybrid	Gasol./el éc.	FWD	1469	96	131	03.22-	*
1.3 D (356HXH1A) (552 66 963)	Diesel	FWD	1248	70	95	03.16-	*

## LISTA DE APLICACIONES - BUYERS GUIDE

1.3 D (356HXH1A) (552 83 775)	Diesel	FWD	1248	70	95	03.16-	*
1.6 D (356HXG11) (552 60 384)	Diesel	FWD	1598	84	114	09.16-10.20	*
1.6 D (356HXG11) (552 80 444)	Diesel	FWD	1598	84	114	09.16-10.20	*
1.6 D (356HXG1B, 356HXG11) (552 60 384)	Diesel	FWD	1598	88	120	03.16-10.20	*
1.6 D (356HXG1B, 356HXG11) (552 80 444)	Diesel	FWD	1598	88	120	03.16-10.20	*
1.6 Multijet (357HXG1)	Diesel	FWD	1598	96	131	11.20-	*
<b>TIPO / EGEA (356_, 357_) 10.15-</b>				<b>Sedán (Compact car-C Segment)</b>			
1.0 (357SXN1A)	Gasolina	FWD	999	74	101	11.20-	*
1.4 (356SXA1B) (843 A1.000)	Gasolina	FWD	1368	70	95	10.15-	*
1.6 (356SXE11) (552 68 036)	Gasolina	FWD	1598	81	110	10.15-10.20	*
1.5 T4 Hybrid	Gasol./el éc.	FWD	1469	96	131	03.22-	*
1.3 D (356SXB1A, 356SXH1A, 356SXD1A) (199 B1.000)	Diesel	FWD	1248	70	95	10.15-10.20	*
1.3 D (356SXB1A, 356SXH1A, 356SXD1A) (552 66 963)	Diesel	FWD	1248	70	95	10.15-10.20	*
1.3 D (356SXB1A, 356SXH1A, 356SXD1A) (552 83 775)	Diesel	FWD	1248	70	95	10.15-10.20	*
1.6 D (356SXG1B) (552 60 384)	Diesel	FWD	1598	84	114	09.16-10.20	*
1.6 D (356SXG1B) (552 60 384)	Diesel	FWD	1598	88	120	10.15-10.20	*
1.6 D (356SXG1B) (940 C1.000)	Diesel	FWD	1598	88	120	10.15-10.20	*
1.6 Multijet (357SXG1)	Diesel	FWD	1598	96	131	11.20-	*