

# LISTA DE APLICACIONES - BUYERS GUIDE

## RB2246



8 424073 140982

Qty: 300

Weight: 1.860

O.E.M.	MAKE
01 347 830 0	OPEL
039 103 797	OPEL
1 347 830 0	VAUXHALL
1684934780	VAUXHALL
39 103 797	VAUXHALL
95 526 566	OPEL

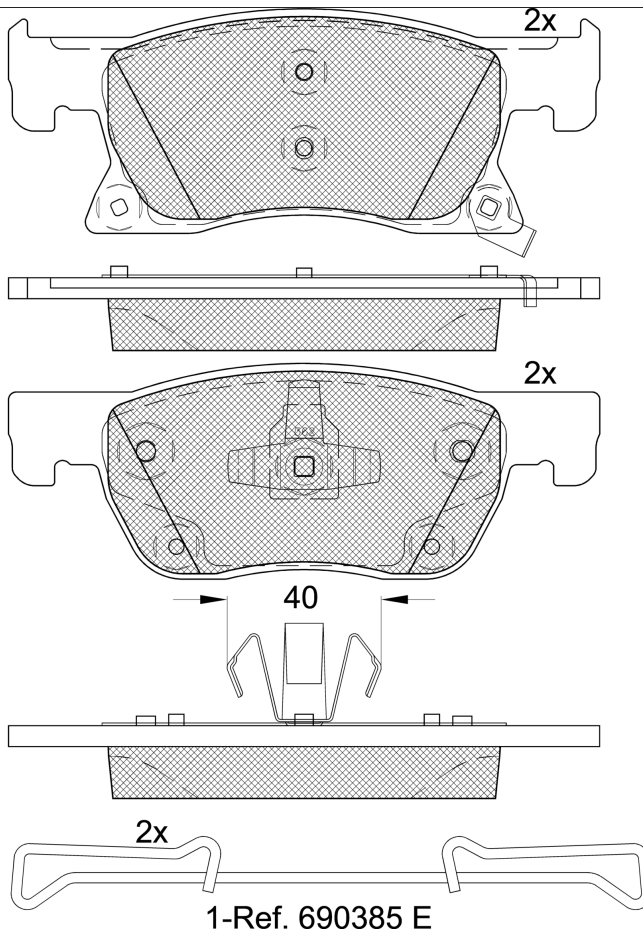

## RB2246

**E 9** 90R-02A0111/4486



Ate - Teves

155.1x56.6x19.8
155.1x58.9x19.8

WVA	FMSI
22342	D2171-9416
22343	

Sin Filas



	Trac.	CC	Kw	CV			
						Front / Rear	

### CHEVROLET

Modelo	Trac.	CC	Kw	CV	Año	Segmento
<b>CRUZE II (J405) 01.17-</b>						<b>[CAMBIADO]:Fastback (Supermini car-B Segment)</b>
1.4 (LE2(85CUL4))	Gasolina	FWD	1399	114 155	01.17-	*
<b>CRUZE II (J400) 11.15-</b>						<b>Sedán (Supermini car-B Segment)</b>
1.4 (LE2(85CUL4))	Gasolina	FWD	1399	110 150	06.16-	*
1.4 (LE2(85CUL4))	Gasolina	FWD	1399	114 155	11.15-	*
1.4 Flex (LE2(85VUL4))	Gasol./Etanol	FWD	1399	113 153	01.17-	*
CDTi (B 16 DTH)	Diesel	FWD	1598	99 135	11.15-	*

### CHEVROLET (SGM)

Modelo	Trac.	CC	Kw	CV	Año	Segmento
<b>CRUZE II (CP3) 08.14-07.16</b>						<b>Sedán (Supermini car-B Segment)</b>
1.4 T	Gasolina	FWD	1399	110 150	08.14-	*
1.5	Gasolina	FWD	1485	80 109	03.14-	*
1.5	Gasolina	FWD	1490	84 114	08.14-	*

### HOLDEN

Modelo	Trac.	CC	Kw	CV	Año	Segmento
<b>ASTRA (BK) 09.17-</b>						<b>[CAMBIADO]:Break (Compact car-C Segment)</b>
1.4 (B 14 XFT)	Gasolina	FWD	1399	110 150	09.17-	*
<b>ASTRA (PJ) 12.14-</b>						<b>[CAMBIADO]:Fastback (Compact car-C Segment)</b>
1.4	Gasolina	FWD	1399	110 150	01.17-	*
1.6 (B 16 SHT)	Gasolina	FWD	1598	147 200	09.16-	*

### OPEL

Modelo	Trac.	CC	Kw	CV	Año	Segmento
<b>ASTRA K (B16) 06.15-</b>						<b>[CAMBIADO]:Fastback (Compact car-C Segment)</b>
1.0 Turbo (68) (D 10 XFL)	Gasolina	FWD	999	66 90	06.18-08.19	*

# LISTA DE APLICACIONES - BUYERS GUIDE

1.0 Turbo (68) (B 10 XFL)		Gasolina	FWD	999	77	105	06.15-08.19	*
1.0 Turbo (68) (D 10 XFL)		Gasolina	FWD	999	77	105	06.15-08.19	*
1.2 Turbo (68) (F 12 SHL)		Gasolina	FWD	1199	81	110	08.19-09.21	*
1.2 Turbo (68) (F 12 SHT)		Gasolina	FWD	1199	96	131	08.19-09.21	*
1.2 Turbo (68) (F 12 SHR)		Gasolina	FWD	1199	107	145	08.19-09.21	*
1.4 Turbo (68) (F 14 SHL)		Gasolina	FWD	1342	107	145	08.19-09.21	*
1.4 Turbo (68) (F 14 SHT)		Gasolina	FWD	1342	107	145	08.19-09.21	*
1.4 (68) (B 14 XE)		Gasolina	FWD	1399	74	100	06.15-08.18	*
1.4 Turbo (68) (B 14 XFL)		Gasolina	FWD	1399	92	125	06.15-08.19	*
1.4 Turbo (68) (B 14 XFT)		Gasolina	FWD	1399	103	140	07.17-	*
1.4 Turbo (68) (B 14 XFT)		Gasolina	FWD	1399	110	150	10.15-08.19	*
1.6 Turbo (68) (B 16 SHT)		Gasolina	FWD	1598	147	200	11.15-02.19	*
1.4 CNG (68) (B 14 XNT)		Gasol./Gas (CNG)	FWD	1399	81	110	10.17-05.18	*
1.5 CRDI (68) (D 15 DVC)		Diesel	FWD	1496	77	105	08.19-09.21	*
1.5 CRDI (68) (F 15 DVC)		Diesel	FWD	1496	77	105	08.19-09.21	*
1.5 CRDI (68) (D 15 DVH)		Diesel	FWD	1496	90	122	08.19-09.21	*
1.5 CRDI (68) (F 15 DVH)		Diesel	FWD	1496	90	122	08.19-09.21	*
1.6 CDTi (68) (B 16 DTE)		Diesel	FWD	1598	70	95	10.15-05.18	*
1.6 CDTi		Diesel	RWD	1598	77	105	06.15-	*
1.6 CDTi (68) (B 16 DTE)		Diesel	FWD	1598	81	110	06.15-08.19	*
1.6 CDTi (68) (B 16 DTU)		Diesel	FWD	1598	81	110	06.15-08.19	*
1.6 CDTi (68) (D 16 DTI)		Diesel	FWD	1598	81	110	06.15-08.19	*
1.6 CDTi (68) (B 16 DTH)		Diesel	FWD	1598	100	136	06.15-08.19	*
1.6 CDTi (68) (D 16 DTH)		Diesel	FWD	1598	100	136	06.15-08.19	*
1.6 BiTurbo (D 16 DTR)		Diesel	FWD	1598	110	150	07.18-02.19	*
1.6 CDTi (68) (B 16 DTR)		Diesel	FWD	1598	118	160	11.15-05.18	*
<b>ASTRA K 11.15-</b>						<b>[CAMBIADO]:Furgón/Break (Compact car-C Segment)</b>		
1.0 (35) (D 10 XFL)		Gasolina	FWD	999	77	105	05.18-08.19	*
1.4 (35) (D 14 XFT)		Gasolina	FWD	1399	110	150	06.18-09.21	*
1.5 CRDI (35) (D 15 DVC)		Diesel	FWD	1496	77	105	08.19-09.21	*
1.5 CRDI (35) (F 15 DVC)		Diesel	FWD	1496	77	105	08.19-09.21	*
<b>ASTRA K 06.15-</b>						<b>Furgón/hatchback (Compact car-C Segment)</b>		
1.6 CDTi (D 16 DTH)		Diesel	FWD	1598	100	136	04.18-08.19	*
<b>ASTRA K 11.15-</b>						<b>Sedán (Compact car-C Segment)</b>		
1.4 LPG		Gasolina	FWD	1364	103	140	11.15-	*
1.4 Turbo		Gasolina	FWD	1364	103	140	11.15-	*
1.6		Gasolina	FWD	1598	85	116	11.15-	*
1.6 CDTi		Diesel	RWD	1598	81	110	11.15-	*
1.6 CDTi		Diesel	RWD	1598	100	136	11.15-	*
<b>ASTRA K Sports Tourer (B16) 11.15-</b>						<b>[CAMBIADO]:Break (Compact car-C Segment)</b>		
1.0 Turbo (35) (D 10 XFL)		Gasolina	FWD	999	66	90	06.18-08.19	*
1.0 Turbo (35) (B 10 XFL)		Gasolina	FWD	999	77	105	06.18-08.19	*
1.0 Turbo (35) (D 10 XFL)		Gasolina	FWD	999	77	105	06.18-08.19	*
1.2 Turbo (35) (F 12 SHL)		Gasolina	FWD	1199	81	110	08.19-12.21	*
1.2 Turbo (35) (F 12 SHT)		Gasolina	FWD	1199	96	131	08.19-12.21	*
1.2 Turbo (35) (F 12 SHR)		Gasolina	FWD	1199	107	145	08.19-12.21	*
1.4 Turbo (35) (F 14 SHL)		Gasolina	FWD	1342	107	145	08.19-12.21	*
1.4 Turbo (35) (F 14 SHT)		Gasolina	FWD	1342	107	145	08.19-12.21	*

# LISTA DE APLICACIONES - BUYERS GUIDE

1.4 (35) (B 14 XE)		Gasolina	FWD	1399	74	100	04.16-05.18	*
1.4 Turbo (35) (B 14 XFL)		Gasolina	FWD	1399	92	125	04.16-08.19	*
1.4 Turbo (35) (B 14 XFT)		Gasolina	FWD	1399	110	150	04.16-08.19	*
1.4 Turbo (35) (D 14 XFT)		Gasolina	FWD	1399	110	150	04.16-08.19	*
1.6 Turbo (35) (B 16 SHT)		Gasolina	FWD	1598	147	200	04.16-02.19	*
1.4 CNG (35) (B 14 XNT)		Gasol./Gas (CNG)	FWD	1399	81	110	08.17-05.18	*
1.5 CRDI (35) (D 15 DVC)		Diesel	FWD	1496	77	105	08.19-12.21	*
1.5 CRDI (35) (F 15 DVC)		Diesel	FWD	1496	77	105	08.19-12.21	*
1.5 CRDI (35) (D 15 DVH)		Diesel	FWD	1496	90	122	08.19-12.21	*
1.5 CRDI (35) (F 15 DVH)		Diesel	FWD	1496	90	122	08.19-12.21	*
1.6 CDTi (35) (B 16 DTE)		Diesel	FWD	1598	70	95	04.16-05.18	*
1.6 CDTi (35) (B 16 DTE)		Diesel	FWD	1598	81	110	04.16-08.19	*
1.6 CDTi (35) (B 16 DTU)		Diesel	FWD	1598	81	110	04.16-08.19	*
1.6 CDTi (35) (D 16 DTI)		Diesel	FWD	1598	81	110	04.16-08.19	*
1.6 CDTi (35) (B 16 DTH)		Diesel	FWD	1598	100	136	04.16-08.19	*
1.6 BiTurbo (D 16 DTR)		Diesel	FWD	1598	110	150	07.18-02.19	*
1.6 CDTi (35) (B 16 DTR)		Diesel	FWD	1598	118	160	04.16-05.18	*

## VAUXHALL

				<b>[CAMBIADO]:Break (Compact car-C Segment)</b>				
<b>ASTRA Mk VII (K) (B16) 07.15-</b>								
1.0 (B 10 XFL)		Gasolina	FWD	999	77	105	04.16-08.19	*
1.0 (D 10 XFL)		Gasolina	FWD	999	77	105	04.16-08.19	*
1.2 Turbo (F 12 SHL)		Gasolina	FWD	1199	81	110	08.19-12.21	*
1.2 Turbo (F 12 SHT)		Gasolina	FWD	1199	96	131	08.19-12.21	*
1.2 Turbo (F 12 SHR)		Gasolina	FWD	1199	107	145	08.19-12.21	*
1.4 Turbo (F 14 SHL)		Gasolina	FWD	1342	107	145	08.19-12.21	*
1.4 Turbo (F 14 SHT)		Gasolina	FWD	1342	107	145	08.19-12.21	*
1.4 (B 14 XE)		Gasolina	FWD	1399	74	100	04.16-05.18	*
1.4 Turbo (B 14 XFL)		Gasolina	FWD	1399	92	125	04.16-05.18	*
1.4 Turbo (B 14 XFT)		Gasolina	FWD	1399	110	150	04.16-08.19	*
1.6 Turbo (B 16 SHT)		Gasolina	FWD	1598	147	200	04.16-02.19	*
1.4 CNG		Gasol./Gas (CNG)	FWD	1399	81	110	10.17-	*
1.5 CRDi (D 15 DVC)		Diesel	FWD	1496	77	105	08.19-12.21	*
1.5 CRDi (F 15 DVC)		Diesel	FWD	1496	77	105	08.19-12.21	*
1.5 CRDi (D 15 DVH)		Diesel	FWD	1496	90	122	08.19-12.21	*
1.5 CRDi (F 15 DVH)		Diesel	FWD	1496	90	122	08.19-12.21	*
1.6 CDTi (B 16 DTE)		Diesel	FWD	1598	70	95	04.16-05.18	*
1.6 CDTi (B 16 DTE)		Diesel	FWD	1598	81	110	07.15-12.21	*
1.6 CDTi (B 16 DTU)		Diesel	FWD	1598	81	110	07.15-12.21	*
1.6 CDTi (D 16 DTI)		Diesel	FWD	1598	81	110	07.15-12.21	*
1.6 CDTi (B 16 DTH)		Diesel	FWD	1598	100	136	04.16-08.19	*
1.6 CDTi (D 16 DTH)		Diesel	FWD	1598	100	136	04.16-08.19	*
1.6 BiTurbo (D 16 DTR)		Diesel	FWD	1598	110	150	07.18-02.19	*
1.6 CDTi (B 16 DTR)		Diesel	FWD	1598	118	160	04.16-05.18	*
<b>ASTRA Mk VII (K) (B16) 06.15-12.21</b>				<b>[CAMBIADO]:Fastback (Compact car-C Segment)</b>				
1.0 (B 10 XFL)		Gasolina	FWD	999	77	105	04.16-08.19	*
1.0 (D 10 XFL)		Gasolina	FWD	999	77	105	04.16-08.19	*
1.2 Turbo (F 12 SHL)		Gasolina	FWD	1199	81	110	08.19-12.21	*
1.2 Turbo (F 12 SHT)		Gasolina	FWD	1199	96	131	08.19-12.21	*

## LISTA DE APLICACIONES - BUYERS GUIDE

1.2 Turbo (F 12 SHR)		Gasolina	FWD	1199	107	145	08.19-12.21	*
1.4 Turbo (F 14 SHL)		Gasolina	FWD	1342	107	145	08.19-12.21	*
1.4 Turbo (F 14 SHT)		Gasolina	FWD	1342	107	145	08.19-12.21	*
1.4 (B 14 XE)		Gasolina	FWD	1399	74	100	04.16-05.18	*
1.4 Turbo (B 14 XFL)		Gasolina	FWD	1399	92	125	04.16-05.18	*
1.4 Turbo (B 14 XFT)		Gasolina	FWD	1399	110	150	04.16-08.19	*
1.6 Turbo (B 16 SHT)		Gasolina	FWD	1598	147	200	04.16-02.19	*
1.4 CNG		Gasol./Gas (CNG)	FWD	1399	81	110	10.17-	*
1.5 CRDi (D 15 DVC)		Diesel	FWD	1496	77	105	08.19-12.21	*
1.5 CRDi (F 15 DVC)		Diesel	FWD	1496	77	105	08.19-12.21	*
1.5 CRDi (D 15 DVH)		Diesel	FWD	1496	90	122	08.19-09.21	*
1.5 CRDi (F 15 DVH)		Diesel	FWD	1496	90	122	08.19-09.21	*
1.6 CDTi (B 16 DTE)		Diesel	FWD	1598	70	95	10.15-05.18	*
1.6 CDTi (B 16 DTE)		Diesel	FWD	1598	81	110	06.15-08.19	*
1.6 CDTi (B 16 DTU)		Diesel	FWD	1598	81	110	06.15-08.19	*
1.6 CDTi (D 16 DTI)		Diesel	FWD	1598	81	110	06.15-08.19	*
1.6 CDTi (B 16 DTH)		Diesel	FWD	1598	100	136	06.15-08.19	*
1.6 CDTi (D 16 DTH)		Diesel	FWD	1598	100	136	06.15-08.19	*
1.6 BiTurbo (D 16 DTR)		Diesel	FWD	1598	110	150	07.18-02.19	*
1.6 CDTi (B 16 DTR)		Diesel	FWD	1598	118	160	11.15-05.18	*