

LISTA DE APLICACIONES - BUYERS GUIDE

RB2218



8 424073 139726

Qty: 300

Weight: 2.445

O.E.M.	MAKE
000 420 38 00	MERCEDES-BENZ
000 420 38 20	MERCEDES-BENZ
007 420 42 20	MERCEDES-BENZ

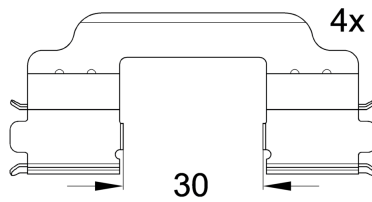
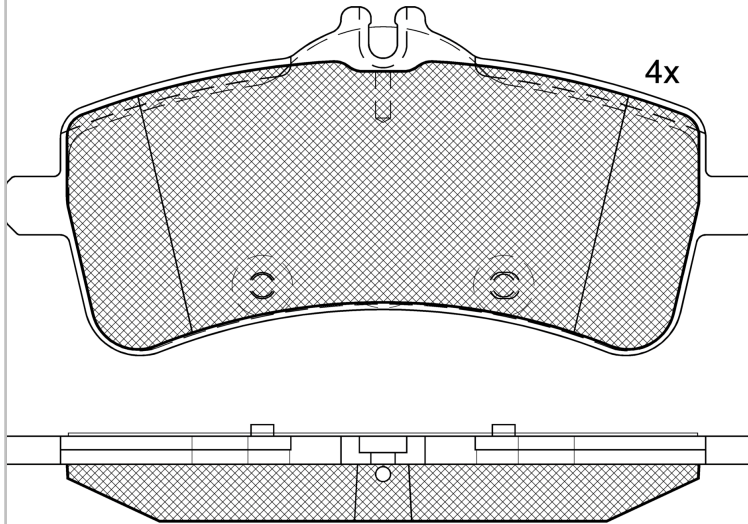

1-Ref. 690314 E

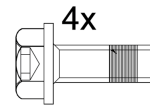

1-Ref. 690173 E

RB2218

E 9 90R-02A0111/4340



Trw

161.9x74.8x18.9

WVA

25587

FMSI

D2103-9336

Sin Filas



Trac.	CC	Kw	CV
-------	----	----	----



Front / Rear

MERCEDES-BENZ

S-Class VI (W222, V222, X222) 05.13-

Sedán (Luxury car-F Segment)

S 400 Maybach 4-matic (222.967) (M 276.824)	Gasolina	4WD	2996	245	333	01.15-05.17	*
S 450 4-matic (222.064, 222.164) (M 276.824)	Gasolina	4WD	2996	270	367	02.17-07.20	*
S 450 Maybach 4-matic (222.964) (M 276.824)	Gasolina	4WD	2996	270	367	09.17-07.20	*
S 560 Maybach (222.983) (M 176.980)	Gasolina	RWD	3982	345	469	07.17-07.20	*
S 560 Maybach 4-matic (222.986) (M 176.980)	Gasolina	4WD	3982	345	469	07.17-07.20	*
S 500 Maybach	Gasolina	FWD	3996	310	421	09.15-	*
S 500 (222.082, 222.182) (M 278.929)	Gasolina	RWD	4663	320	435	07.13-05.17	*
S 500 4-matic (222.185) (M 278.929)	Gasolina	4WD	4663	320	435	09.13-05.17	*
S 500 (222.082, 222.182) (M 278.929)	Gasolina	RWD	4663	335	455	05.13-05.17	*
S 500 4-matic (222.085, 222.185) (M 278.929)	Gasolina	4WD	4663	335	455	05.13-05.17	*
S 500 Maybach (222.982) (M 278.929)	Gasolina	RWD	4663	335	455	12.14-05.17	*
S 500 Maybach 4-matic (222.985) (M 278.929)	Gasolina	4WD	4663	335	455	04.15-05.17	*
S 500 (222.182)	Gasolina	RWD	4663	338	460	06.14-	*
S 500 Maybach (222.982)	Gasolina	RWD	4663	338	460	12.14-	*
S 63 AMG (222.077, 222.177) (M 157.985)	Gasolina	RWD	5461	430	585	05.13-05.17	*
S 63 AMG 4-matic (222.178) (M 157.985)	Gasolina	4WD	5461	430	585	05.13-05.17	*
S 600 (222.176) (M 277.980)	Gasolina	RWD	5980	390	530	02.14-07.20	*
S 600 Maybach (222.976) (M 277.980)	Gasolina	RWD	5980	390	530	12.14-11.18	*
S 650 Maybach (222.980)	Gasolina	RWD	5980	390	530	03.19-07.20	*
S 650 Maybach (222.980) (M 279.980)	Gasolina	RWD	5980	463	630	07.17-07.20	*
S 65 AMG (222.179) (M 279.980)	Gasolina	RWD	5980	463	630	02.14-11.19	*

LISTA DE APLICACIONES - BUYERS GUIDE

S-Class VII (V223) 09.20-					Sedán (Luxury car-F Segment)			
S 450 EQ Boost 4-matic (223.161)		Gasol./el éc.	4WD	2999	270	367	10.20-	*
S 580 e (223.168)		Gasol./el éc.	RWD	2999	270	367	07.21-	*
S 450 EQ Boost 4-matic (223.161)		Gasol./el éc.	4WD	2999	280	381	09.22-	*
S 450 e (223.166)		Gasol./el éc.	RWD	2999	300	408	05.22-	*
S 500 EQ Boost 4-matic (223.163)		Gasol./el éc.	4WD	2999	320	435	09.20-	*
S 500 EQ Boost 4-matic (223.163)		Gasol./el éc.	4WD	2999	330	449	09.22-	*
S 580 e (223.168)		Gasol./el éc.	RWD	2999	375	510	07.21-	*
S 580 e 4-matic (223.069)		Gasol./el éc.	4WD	2999	375	510	11.21-	*
S 580 e 4-matic (223.169) (M 256.930)		Gasol./el éc.	4WD	2999	375	510	07.21-	*
S 580 4-matic (223.176)		Gasol./el éc.	4WD	3982	370	503	05.21-	*
S 63 AMG Hybrid 4-matic (223.182)		Gasol./el éc.	4WD	3982	590	802	05.23-	*
S 350 d Mild Hybrid (223.120)		Diesel/el éc.	RWD	2989	230	313	05.23-	*
S 350 d Mild Hybrid 4-matic (223.121)		Diesel/el éc.	4WD	2989	230	313	05.23-	*
S 450 d Mild Hybrid 4-matic (223.123)		Diesel/el éc.	4WD	2989	270	367	05.23-	*
S 350 d (223.130)		Diesel	RWD	2925	210	286	09.20-	*
S 350 d 4-matic (223.131)		Diesel	4WD	2925	210	286	09.20-	*
S 400 d 4-matic (223.133)		Diesel	4WD	2925	243	330	09.20-	*