

LISTA DE APLICACIONES - BUYERS GUIDE

RB2194



8 424073 139467

Qty: 300

Weight: 3.015

O.E.M.	MAKE
006 420 93 20	MERCEDES-BENZ
008 420 09 20-oe	MERCEDES-BENZ

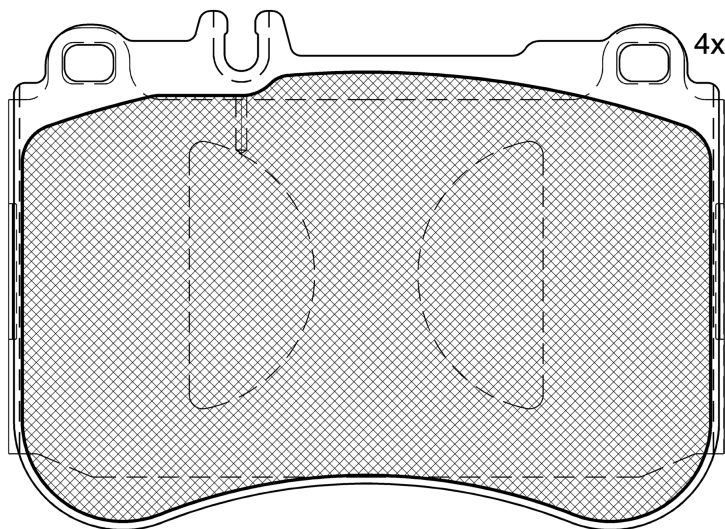

RB2194

E 9 90R-02A0111/4147



Brembo

131.4x95.3x18

WVA
25179
25705

FMSI
D1782-8915

Sin Filas



Trac.	CC	Kw	CV
-------	----	----	----



Front / Rear

MERCEDES-BENZ

S-Class VI (C217) 04.14-

Coupé (Luxury car-F Segment)

Model	Gasolina	Trac.	CC	Kw	CV	Year	*
S500	Gasolina	FWD	3996	310	422	11.14-	*
S 500 4-matic (217.385) (M 278.929)	Gasolina	4WD	4663	335	455	04.14-10.17	*
S 63 AMG 4-matic (217.378) (M 157.985)	Gasolina	4WD	5461	430	585	04.14-10.17	*

S-Class VI (W222, V222, X222) 05.13-

Sedán (Luxury car-F Segment)

Model	Gasolina	Trac.	CC	Kw	CV	Year	*
S 63 AMG (222.077, 222.177) (M 157.985)	Gasolina	RWD	5461	430	585	05.13-05.17	*
S 63 AMG 4-matic (222.178) (M 157.985)	Gasolina	4WD	5461	430	585	05.13-05.17	*