

LISTA DE APLICACIONES - BUYERS GUIDE

RB2155-066

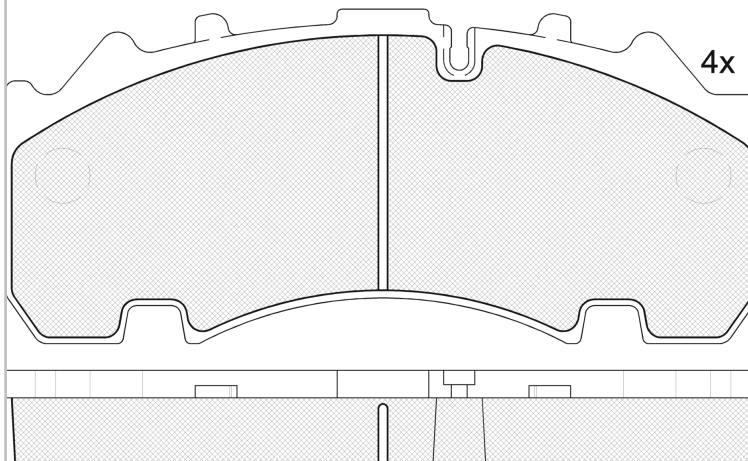

Qty: 660 Weight: 10.750



RB2155-066

E 9 90R-02A0178/3910



Knorr SN7

247.4x109.6x30

WVA

29167

29216

29263

29270

29307

Sin Filas

O.E.M.	MAKE
05.092.90.07.0	BPW
05.092.90.09.0	BPW
05.362.70.02.0	BPW
09.801.02.57.0	BPW
09.801.02.92.0	BPW
09.801.06.20.0	BPW
09.801.06.36.0	BPW
09.801.06.45.0	BPW
09.801.06.96.0	BPW
09.801.07.25.0	BPW
09.801.07.28.0	BPW
09.801.08.17.0	BPW
K 003 966	BPW



1-Ref. 690067 E1

4x



1-Ref. 690128 E



Trac.	CC	Kw	CV
-------	----	----	----



Front / Rear

BPW

SH 01.96-

Eje remolque

SHBF 9010 ECO Plus					01.00-	*
SHSF 10010-15 ECO					01.96-	*
SHSF 10010-15 ECO-MAXX					01.96-	*
SHSF 10010-15 ECO Plus					01.96-	*
SHSF 10110-15 ECO					01.96-	*
SHSF 10110-15 ECO-MAXX					01.96-	*
SHSF 10110-15 ECO Plus					01.96-	*
SHSF 12010-16 ECO-MAXX					01.96-	*
SHSF 12010-16 ECO Plus					01.96-	*
SHSF 9010					01.96-	*
SHSF 9010-15 ECO					01.96-	*
SHSF 9010-15 ECO-MAXX					01.96-	*
SHSF 9010-15 ECO Plus					01.96-	*
SHSF 9010 ECO					01.96-	*
SHSF 9010 ECO-MAXX					01.96-	*
SHSF 9010 ECO Plus					01.96-	*
SHSF 9010 ECO Plus					01.00-	*
SHSFA 8010 ECO-MAXX					01.96-	*
SHSFA 9010-15 ECO-MAXX					01.96-	*
SHSFA 9010 ECO					01.96-	*
SHSFA 9010 ECO-MAXX					01.96-	*
SHSFH 9010 ECO-MAXX					01.97-	*
SHSM 10010-15 ECO					01.96-	*

LISTA DE APLICACIONES - BUYERS GUIDE

SHSM 10010-15 ECO-MAXX						01.96-	*
SHSM 10010-15 ECO Plus						01.96-	*
SHSM 10110-15 ECO						01.96-	*
SHSM 10110-15 ECO-MAXX						01.96-	*
SHSM 10110-15 ECO Plus						01.96-	*
SHSM 12010-16 ECO-MAXX						01.96-	*
SHSM 12010-16 ECO Plus						01.96-	*
SHSM 9010-15 ECO-MAXX						01.96-	*
SHSM 9010-15 ECO Plus						01.00-	*
SHSM 9010 ECO						01.96-	*
SHSM 9010 ECO-MAXX						01.96-	*
SHSM 9010 ECO Plus						01.00-	*
SHSMA 9010 ECO						01.96-	*
SHZ 12010-16 ECO-MAXX						01.96-	*
SHZF 10010-15 ECO						01.96-	*
SHZF 10010-15 ECO-MAXX						01.96-	*
SHZF 10010-15 ECO Plus						01.96-	*
SHZF 10110-15 ECO						01.96-	*
SHZF 10110-15 ECO-MAXX						01.96-	*
SHZF 10110-15 ECO Plus						01.96-	*
SHZF 12010-16 ECO-MAXX						01.96-	*
SHZF 12010-16 ECO Plus						01.96-	*
SHZF 14010-15 ECO-MAXX						01.96-	*
SHZF 14010-1 ECO-MAXX						01.96-	*
SHZF 9010-15 ECO						01.96-	*
SHZF 9010-15 ECO-MAXX						01.96-	*
SHZF 9010-15 ECO Plus						01.96-	*
SHZF 9010 ECO						01.96-	*
SHZF 9010 ECO-MAXX						01.96-	*
SHZF 9010 ECO Plus						01.00-	*
SHZM 10010-15 ECO						01.96-	*
SHZM 10010-15 ECO-MAXX						01.96-	*
SHZM 10110-15 ECO						01.96-	*
SHZM 10110-15 ECO-MAXX						01.96-	*
SHZM 10110-15 ECO Plus						01.96-	*
SHZM 12010-16 ECO-MAXX						01.96-	*
SHZM 12010-16 ECO Plus						01.96-	*
SHZM 9010-15 ECO-MAXX						01.96-	*
SHZM 9010-15 ECO Plus						01.00-	*
SHZMA 9010-15 ECO-MAXX						01.96-	*