

LISTA DE APLICACIONES - BUYERS GUIDE

RB2113-202



Qty: 300 Weight: 2.790

O.E.M.	MAKE
5S0 698 151 C	AUDI
8E0 698 151 P	AUDI
8E0 698 151 Q	AUDI

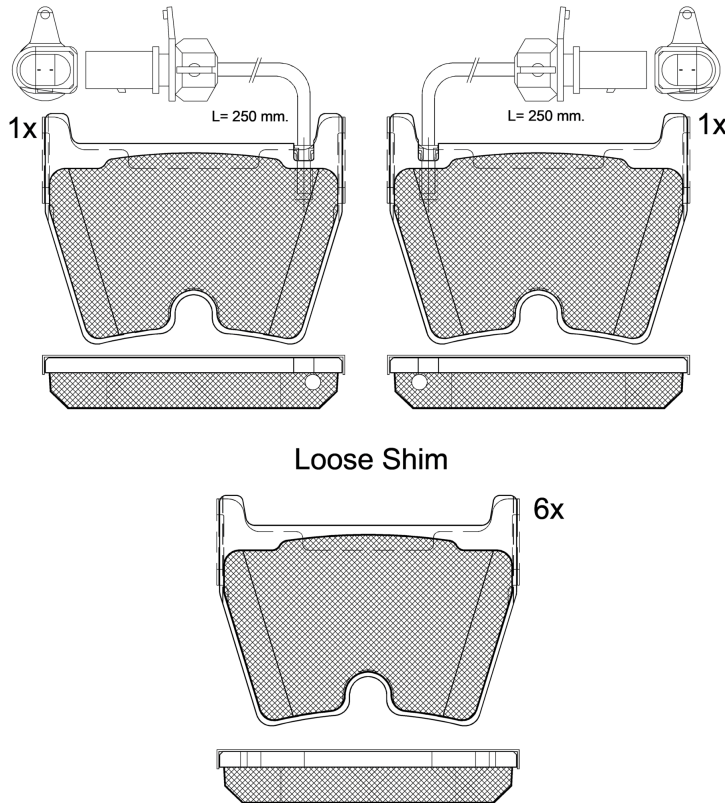

RB2113-202

E 9 90R-02A0111/5016



Brembo

95.5x74x17

WVA
22082
22084
22085
23751
24516

Sin Filas



Trac.	CC	Kw	CV
-------	----	----	----



AUDI

							[CAMBIADO]:Break (Compact executive car-D Segment)			
A4 III B7 Avant (8ED) 11.04-11.08										
RS4 quattro (BNS)		Gasolina	4WD	4163	309	420	09.05-06.08	*		
A4 III B7 (8HE) 01.02-01.10							Cabrío (Compact executive car-D Segment)			
RS4 quattro (BNS)		Gasolina	4WD	4163	309	420	02.06-12.08	*		
A4 III B7 (8EC) 11.04-01.09							Sedán (Compact executive car-D Segment)			
RS4 quattro (BNS)		Gasolina	4WD	4163	309	420	09.05-06.08	*		
R8 (422, 423) 04.07-12.16							Coupé (Sports car-S Segment)			
4.2 FSI quattro (BYH)		Gasolina	4WD	4163	309	420	04.07-09.10	*		