

LISTA DE APLICACIONES - BUYERS GUIDE

78RBD29060



Weight: 13.404

O.E.M.	MAKE
5 69 060	OPEL
90 539 466	VAUXHALL
91 176 78	VAUXHALL

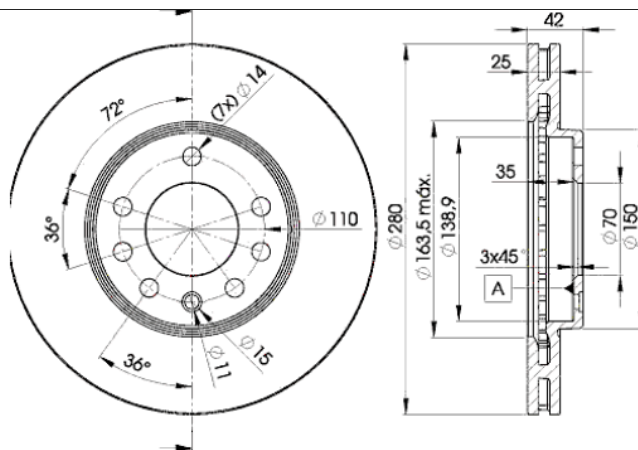

78RBD29060

E1 90R-02C0452/0118



Ø280x25x42

Sin Filas



Trac.	CC	Kw	CV
-------	----	----	----



Front / Rear

CHEVROLET

						[CAMBIADO]:Break (Compact car-C Segment)		
ASTRA 09.94-12.11								
1.8 GLS		Gasolina	FWD	1796	81	110	08.02-12.11	*
2.0 (X 20 XEV)		Gasolina	FWD	1998	94	128	10.99-07.02	*
2.0 (C 20 SEL)		Gasolina	FWD	1998	100	136	08.02-07.05	*
2.2		Gasolina	FWD	2198	108	147	01.01-12.03	*
ASTRA 09.98-12.11						[CAMBIADO]:Fastback (Compact car-C Segment)		
1.8 (08, 48) (C 18 NE)		Gasolina	FWD	1796	81	110	09.98-12.11	*
1.8 (08, 48) (C 18 YE)		Gasolina	FWD	1796	81	110	09.98-12.11	*
1.8 (08, 48) (LC5(110CUL4))		Gasolina	FWD	1796	81	110	09.98-12.11	*
2.0 (C 20 SEJ)		Gasolina	FWD	1998	82	112	03.99-07.02	*
2.0 (LE4(122CUL4))		Gasolina	FWD	1998	85	116	08.02-12.11	*
2.0 (X 20 XEV)		Gasolina	FWD	1998	94	128	03.99-07.02	*
2.0 (08, 48) (L34(122CUL4))		Gasolina	FWD	1998	100	136	08.02-07.05	*
2.2 (Z 22 SE)		Gasolina	FWD	2198	108	147	08.00-08.04	*
1.7 Di (Y 17 DT)		Diesel	FWD	1686	55	75	08.00-08.03	*
2.0 DTI (LD1)		Diesel	FWD	1995	74	101	08.02-12.11	*
ASTRA 10.98-12.11						Sedán (Compact car-C Segment)		
1.8 Flexfuel (C 18 NE)		Gasolina	FWD	1796	81	110	03.99-12.11	*
1.8 Flexfuel (C 18 YE)		Gasolina	FWD	1796	81	110	03.99-12.11	*
1.8 (2H9)		Gasolina	FWD	1796	92	125	08.02-06.05	*
2.0 GL (LE4(122CUL4))		Gasolina	FWD	1998	82	112	10.98-07.02	*
2.0 GL (LE4(122CUL4))		Gasolina	FWD	1998	85	116	08.02-12.11	*
2.0 GLS (X 20 XEV)		Gasolina	FWD	1998	94	128	03.99-07.02	*

LISTA DE APLICACIONES - BUYERS GUIDE

2.0 GLS (69) (C 20 SEL)		Gasolina	FWD	1998	100	136	08.02-12.11	*
2.0 GLS (69) (L34(122CUL4))		Gasolina	FWD	1998	100	136	08.02-12.11	*
2.0 DTi GLS (LD1)		Diesel	FWD	1995	74	101	08.02-12.11	*
VIVA 09.03-03.08					Sedán (Compact car-C Segment)			
1.8		Gasolina	FWD	1796	90	122	09.03-03.08	*
1.8 (2H9)		Gasolina	FWD	1796	92	125	09.03-03.08	*
ZAFIRA / NABIRA (F75) 02.99-12.12					MPV (Compact MPV-M1 Segment)			
1.8 (C 18 YE)		Gasolina	FWD	1796	81	110	02.99-07.01	*
2.0 (LE4(122CUL4))		Gasolina	FWD	1998	85	116	04.01-07.04	*
2.0 (X 20 XE)		Gasolina	FWD	1998	89	121	08.04-12.12	*
2.0 (C 20 SEL)		Gasolina	FWD	1998	100	136	04.01-07.12	*
2.0 (L34(122CUL4))		Gasolina	FWD	1998	100	136	04.01-07.12	*
2.2		Gasolina	FWD	2198	91	124	04.01-07.04	*
2.2 (Z 22 YH)		Gasolina	FWD	2198	110	150	09.05-12.06	*
OPEL								
ASTRA G (T98) 02.98-07.05					[CAMBIADO]:Break (Compact car-C Segment)			
1.6 (F35) (Z 16 SE)		Gasolina	FWD	1598	62	84	09.00-07.04	*
1.6 16V (F35) (X 16 XEL)		Gasolina	FWD	1598	74	101	02.98-07.04	*
1.6 16V (F35) (Z 16 XE)		Gasolina	FWD	1598	74	101	02.98-07.04	*
1.6 (F35) (Z 16 XEP)		Gasolina	FWD	1598	76	103	12.02-05.04	*
1.8		Gasolina	FWD	1796	81	110	02.03-07.04	*
1.8 16V (F35) (X 18 XE1)		Gasolina	FWD	1796	85	116	02.98-09.00	*
1.8 16V (F35) (Z 18 XE)		Gasolina	FWD	1796	92	125	09.00-07.04	*
2.0 16V (F35) (X 20 XEV)		Gasolina	FWD	1998	100	136	02.98-07.04	*
2.2 16V (F35) (Z 22 SE)		Gasolina	FWD	2198	108	147	03.01-07.04	*
1.6 CNG (F35) (Z 16 YNG)		Gasol./Gas (CNG)	FWD	1598	71	97	03.03-07.04	*
2.0 DI (F35) (X 20 DTL)		Diesel	FWD	1995	60	82	02.98-07.04	*
2.0 DI (F35) (Y 20 DTL)		Diesel	FWD	1995	60	82	02.98-07.04	*
2.0 DTi 16V (F35) (Y 20 DTH)		Diesel	FWD	1995	74	101	08.99-07.04	*
2.2 DTi (F35) (Y 22 DTR)		Diesel	FWD	2172	86	117	09.02-07.04	*
2.2 DTi (F35) (Y 22 DTR)		Diesel	FWD	2172	92	125	09.02-07.04	*
ASTRA G (T98) 02.98-12.09					[CAMBIADO]:Fastback (Compact car-C Segment)			
1.6 16V (F08, F48) (C 16 SEL)		Gasolina	FWD	1598	74	101	02.98-01.05	*
1.6 16V (F08, F48) (X 16 XEL)		Gasolina	FWD	1598	74	101	02.98-01.05	*
1.6 16V (F08, F48) (Z 16 XE)		Gasolina	FWD	1598	74	101	02.98-01.05	*
1.6 (F08, F48) (Z 16 XEP)		Gasolina	FWD	1598	76	103	11.02-01.05	*
1.8 (F08, F48)		Gasolina	FWD	1796	81	110	02.03-01.04	*
1.8 16V (F08, F48) (X 18 XE1)		Gasolina	FWD	1796	85	116	02.98-09.00	*
1.8 16V (F08, F48) (Z 18 XE)		Gasolina	FWD	1796	92	125	09.00-01.05	*
2.0 16V (F08, F48) (X 20 XEV)		Gasolina	FWD	1998	100	136	02.98-01.05	*
2.2 16V (F08, F48) (Z 22 SE)		Gasolina	FWD	2198	108	147	06.00-01.05	*
1.6 LPG (F08, F48) (X 16 XEL)		Gasol./Gas (LPG)	FWD	1598	74	101	03.98-01.05	*
1.6 LPG (F08, F48) (Z 16 XE)		Gasol./Gas (LPG)	FWD	1598	74	101	03.98-01.05	*
2.0 DI (F08, F48) (X 20 DTL)		Diesel	FWD	1995	60	82	02.98-01.05	*
2.0 DI (F08, F48) (Y 20 DTL)		Diesel	FWD	1995	60	82	02.98-01.05	*
2.0 DTi 16V (F08, F48) (Y 20 DTH)		Diesel	FWD	1995	74	101	08.99-01.05	*
2.2 DTi (F08, F48) (Y 22 DTR)		Diesel	FWD	2172	86	117	09.02-01.05	*

LISTA DE APLICACIONES - BUYERS GUIDE

2.2 DTI (F08, F48) (Y 22 DTR)	Diesel	FWD	2172	92	125	09.02-01.05	*
ASTRA G (F70) 09.98-04.05				[CAMBIADO]:Furgón/Break (Compact car-C Segment)			
2.0 DI (F70) (X 20 DTL)	Diesel	FWD	1995	60	82	01.99-04.05	*
2.0 DI (F70) (Y 20 DTL)	Diesel	FWD	1995	60	82	01.99-04.05	*
2.0 DTI (F70) (Y 20 DTH)	Diesel	FWD	1995	74	101	09.00-04.05	*
ASTRA G (T98) 03.01-10.05				Cabrió (Compact car-C Segment)			
1.6 16V (F67) (Z 16 XE)	Gasolina	FWD	1598	74	101	03.01-10.05	*
1.6 (F67) (Z 16 XEP)	Gasolina	FWD	1598	76	103	01.03-10.05	*
1.8 16V (F67) (Z 18 XE)	Gasolina	FWD	1796	92	125	03.01-10.05	*
2.2 16V (F67) (Z 22 SE)	Gasolina	FWD	2198	108	147	03.01-10.05	*
2.2 DTI (F67) (Y 22 DTR)	Diesel	FWD	2172	92	125	09.02-10.05	*
ASTRA G (T98) 03.00-06.06				Coupé (Compact car-C Segment)			
1.6 16V (F07) (Z 16 XE)	Gasolina	FWD	1598	74	101	03.00-05.05	*
1.6 16V (F07) (Z 16 XEP)	Gasolina	FWD	1598	76	103	03.00-05.05	*
1.8 16V (F07) (X 18 XE1)	Gasolina	FWD	1796	85	116	03.00-10.00	*
1.8 16V (F07) (Z 18 XE)	Gasolina	FWD	1796	92	125	09.00-05.05	*
2.2 16V (F07) (Z 22 SE)	Gasolina	FWD	2198	108	147	09.00-05.05	*
2.2 DTI (F07) (Y 22 DTR)	Diesel	FWD	2172	92	125	09.02-05.05	*
ASTRA G (T98) 03.98-12.09				Sedán (Compact car-C Segment)			
1.6 16V (F69) (X 16 XEL)	Gasolina	FWD	1598	74	101	09.98-01.05	*
1.6 16V (F69) (Z 16 XE)	Gasolina	FWD	1598	74	101	09.98-01.05	*
1.6 (F69) (Z 16 XEP)	Gasolina	FWD	1598	76	103	12.02-12.09	*
1.8	Gasolina	FWD	1796	81	110	02.03-01.05	*
1.8 16V (F69) (X 18 XE1)	Gasolina	FWD	1796	85	116	09.98-09.00	*
1.8 16V (F69) (Z 18 XE)	Gasolina	FWD	1796	92	125	06.00-01.05	*
2.0 16V (F69) (X 20 XEV)	Gasolina	FWD	1998	100	136	09.98-01.05	*
2.2 16V (F69) (Z 22 SE)	Gasolina	FWD	2198	108	147	03.01-01.05	*
1.6 LPG (F69) (X 16 XEL)	Gasol./Gas (LPG)	FWD	1598	74	101	06.02-01.05	*
1.6 LPG (F69) (Z 16 XE)	Gasol./Gas (LPG)	FWD	1598	74	101	06.02-01.05	*
2.0 DI (F69) (X 20 DTL)	Diesel	FWD	1995	60	82	09.98-01.05	*
2.0 DI (F69) (Y 20 DTL)	Diesel	FWD	1995	60	82	09.98-01.05	*
2.0 DTI 16V (F69) (Y 20 DTH)	Diesel	FWD	1995	74	101	08.99-01.05	*
2.2 DTI (F69) (Y 22 DTR)	Diesel	FWD	2172	86	117	09.02-01.05	*
2.2 DTI (F69) (Y 22 DTR)	Diesel	FWD	2172	92	125	09.02-01.05	*
ASTRA H (A04) 08.04-10.10				[CAMBIADO]:Break (Compact car-C Segment)			
1.4 (L35) (Z 14 XEL)	Gasolina	FWD	1364	55	75	08.04-10.10	*
1.6 (L35) (A 16 XER)	Gasolina	FWD	1598	85	116	11.06-10.10	*
1.6 (L35) (Z 16 XER)	Gasolina	FWD	1598	85	116	11.06-10.10	*
1.8 (L35) (Z 18 XE)	Gasolina	FWD	1796	92	125	08.04-10.10	*
1.8 (L35) (A 18 XER)	Gasolina	FWD	1796	103	140	11.05-10.10	*
1.8 (L35) (Z 18 XER)	Gasolina	FWD	1796	103	140	11.05-10.10	*
1.4 LPG (L35) (Z 14 XEP)	Gasol./Gas (LPG)	FWD	1364	66	90	08.09-10.10	*
1.6 LPG (L35) (Z 16 XER)	Gasol./Gas (LPG)	FWD	1598	85	116	08.09-10.10	*
1.3 CDTI (L35) (Z 13 DTH)	Diesel	FWD	1248	66	90	08.05-10.10	*
1.7 CDTI (L35) (Z 17 DTL)	Diesel	FWD	1686	59	80	08.04-10.10	*
1.7 CDTI (L35) (Z 17 DTH)	Diesel	FWD	1686	74	101	08.04-10.10	*
1.7 CDTI (L35) (A 17 DTJ)	Diesel	FWD	1686	81	110	12.08-10.10	*

LISTA DE APLICACIONES - BUYERS GUIDE

1.7 CDTI (L35) (Z 17 DTJ)		Diesel	FWD	1686	81	110	12.08-10.10	*
ASTRA H (A04) 01.04-01.11				[CAMBIADO]:Fastback (Compact car-C Segment)				
1.8 (L48) (Z 18 XE)		Gasolina	FWD	1796	92	125	01.04-10.10	*
1.8 (L48) (A 18 XER)		Gasolina	FWD	1796	103	140	01.06-10.10	*
1.8 (L48) (Z 18 XER)		Gasolina	FWD	1796	103	140	01.06-10.10	*
1.3 CDTI (L48) (Z 13 DTH)		Diesel	FWD	1248	66	90	08.05-10.10	*
1.7 CDTI (L48) (Z 17 DTL)		Diesel	FWD	1686	59	80	03.04-10.10	*
1.7 CDTI (L48) (Z 17 DTH)		Diesel	FWD	1686	74	100	03.04-10.10	*
1.7 CDTI (L48) (A 17 DTJ)		Diesel	FWD	1686	81	110	04.07-09.09	*
1.7 CDTI (L48) (Z 17 DTJ)		Diesel	FWD	1686	81	110	04.07-09.09	*
1.9 CDTI (L48) (Z 19 DTL)		Diesel	FWD	1910	74	100	09.05-10.10	*
ASTRA H (L70) 02.04-10.14				[CAMBIADO]:Furgón/Break (Compact car-C Segment)				
1.4 EcoTec (L70) (Z 14 XEP)		Gasolina	FWD	1364	66	90	12.04-12.12	*
1.6 EcoTec (L70) (Z 16 XEP)		Gasolina	FWD	1598	76	103	02.04-11.04	*
1.6 EcoTec (L70) (Z 16 XER)		Gasolina	FWD	1598	85	116	10.06-12.10	*
1.3 CDTI (L70) (Z 13 DTH)		Diesel	FWD	1248	66	90	08.05-10.10	*
1.7 CDTI (L70) (Z 17 DTL)		Diesel	FWD	1686	59	80	12.04-07.07	*
1.7 CDTI (L70) (Z 17 DTH)		Diesel	FWD	1686	74	101	03.04-10.10	*
1.7 CDTI (L70) (A 17 DTJ)		Diesel	FWD	1686	81	110	02.07-10.14	*
1.7 CDTI (L70) (Z 17 DTJ)		Diesel	FWD	1686	81	110	02.07-10.14	*
1.7 CDTI (L70) (A 17 DTR)		Diesel	FWD	1686	92	125	02.07-10.10	*
1.7 CDTI (L70) (Z 17 DTR)		Diesel	FWD	1686	92	125	02.07-10.10	*
1.9 CDTI (L70) (Z 19 DTL)		Diesel	FWD	1910	74	101	08.05-12.12	*
1.9 CDTI (L70) (Z 19 DT)		Diesel	FWD	1910	88	120	09.05-10.10	*
1.9 CDTI 16V (L70) (Z 19 DTJ)		Diesel	FWD	1910	88	120	08.04-10.10	*
1.9 CDTI (L70) (Z 19 DTH)		Diesel	FWD	1910	110	150	09.04-10.10	*
ASTRA H (A04) 02.07-12.13				Sedán (Compact car-C Segment)				
1.4 (L69) (Z 14 XEP)		Gasolina	FWD	1364	66	90	02.07-06.10	*
1.6 (L69) (Z 16 XEP)		Gasolina	FWD	1598	77	105	02.07-06.10	*
1.8 (L69) (A 18 XER)		Gasolina	FWD	1796	103	140	02.07-06.10	*
1.8 (L69) (Z 18 XER)		Gasolina	FWD	1796	103	140	02.07-06.10	*
1.3 CDTi (L69) (Z 13 DTH)		Diesel	FWD	1248	66	90	02.07-10.10	*
1.7 CDTi (L69) (Z 17 DTH)		Diesel	FWD	1686	74	101	02.07-10.10	*
1.7 CDTi (L69) (Z 17 DTJ)		Diesel	FWD	1686	81	110	02.07-06.10	*
ASTRA H CLASSIC (A04) 01.09-05.14				[CAMBIADO]:Break (Compact car-C Segment)				
1.4 (L35) (Z 14 XEP)		Gasolina	FWD	1364	66	90	01.09-05.14	*
1.6 (L35) (Z 16 XER)		Gasolina	FWD	1598	85	116	01.09-05.14	*
1.8 (L35) (Z 18 XER)		Gasolina	FWD	1796	103	140	01.12-05.14	*
1.7 CDTI (L35) (Z 17 DTJ)		Diesel	FWD	1686	81	110	01.09-05.14	*
ASTRA H CLASSIC (A04) 01.09-				[CAMBIADO]:Fastback (Compact car-C Segment)				
1.4 (L48) (Z 14 XEP)		Gasolina	FWD	1364	66	90	01.09-05.14	*
1.3 CDTI (L48) (Z 13 DTH)		Diesel	FWD	1248	66	90	01.09-05.14	*
1.7 CDTI (L48) (A 17 DTJ)		Diesel	FWD	1686	81	110	01.09-05.14	*
1.7 CDTI (L48) (Z 17 DTJ)		Diesel	FWD	1686	81	110	01.09-05.14	*
ASTRA H CLASSIC (A04) 01.09-05.14				Sedán (Compact car-C Segment)				
1.6 (L69) (Z 16 XER)		Gasolina	FWD	1598	85	116	01.09-05.14	*
1.8 (L69) (Z 18 XER)		Gasolina	FWD	1796	103	140	01.09-09.12	*
1.7 CDTi (L69) (Z 17 DTJ)		Diesel	FWD	1686	81	110	01.09-05.14	*

LISTA DE APLICACIONES - BUYERS GUIDE

1.7 CDTi (L69) (A 17 DTR)		Diesel	FWD	1686	92	125	01.09-05.14	*
1.7 CDTi (L69) (Z 17 DTR)		Diesel	FWD	1686	92	125	01.09-05.14	*
ASTRA H GTC (A04) 03.05-10.10					[CAMBIADO]:Fastback (Compact car-C Segment)			
1.4 (L08) (Z 14 XEL)		Gasolina	FWD	1364	55	75	03.05-10.10	*
1.8 (L08) (Z 18 XE)		Gasolina	FWD	1796	92	125	03.05-10.10	*
1.8 (L08) (Z 18 XER)		Gasolina	FWD	1796	103	140	01.06-10.10	*
1.3 CDTi (L08) (Z 13 DTH)		Diesel	FWD	1248	66	90	04.05-10.10	*
1.7 CDTi (L08) (Z 17 DTL)		Diesel	FWD	1686	59	80	03.05-10.10	*
1.7 CDTi (L08) (Z 17 DTH)		Diesel	FWD	1686	74	101	03.05-10.10	*
1.7 CDTi (L08) (A 17 DTJ)		Diesel	FWD	1686	81	110	02.07-10.10	*
1.7 CDTi (L08) (Z 17 DTJ)		Diesel	FWD	1686	81	110	02.07-10.10	*
ASTRA H TwinTop (A04) 09.05-12.13					Cabrío (Compact car-C Segment)			
1.4 (L67) (Z 14 XEP)		Gasolina	FWD	1364	66	90	10.05-10.10	*
1.8 (L67) (Z 18 XE)		Gasolina	FWD	1796	92	125	09.05-10.10	*
1.8 (L67) (A 18 XER)		Gasolina	FWD	1796	103	140	09.05-10.10	*
1.8 (L67) (Z 18 XER)		Gasolina	FWD	1796	103	140	09.05-10.10	*
COMBO C 10.01-					Furgoneta/MPV (LCVs-N1 Segment)			
1.7 CDTi 16V (Z 17 DTH)		Diesel	FWD	1686	74	101	12.04-	*
COMBO C Tour 10.01-					MPV (Large MPV-M1 Segment)			
1.7 CDTi 16V (Z 17 DTH)		Diesel	FWD	1686	74	101	07.04-12.11	*
MERIVA A (X03) 05.03-05.10					MPV (Mini MPV-M1 Segment)			
1.4 16V Twinport LPG (E75) (Z 14 XEP)		Gasol./Gas (LPG)	FWD	1364	66	90	07.04-05.10	*
1.7 CDTi (E75) (Z 17 DT)		Diesel	FWD	1686	74	100	09.03-05.10	*
1.7 CDTi (E75) (Z 17 DTH)		Diesel	FWD	1686	74	100	09.03-05.10	*
1.7 CDTi (E75) (Z 17 DTR)		Diesel	FWD	1686	92	125	09.06-05.10	*
MERIVA B (S10) 06.10-					MPV (Mini MPV-M1 Segment)			
1.4 (75) (A 14 NEL)		Gasolina	FWD	1364	88	120	06.10-03.17	*
1.4 (75) (B 14 NEL)		Gasolina	FWD	1364	88	120	06.10-03.17	*
1.4 (75) (A 14 XER)		Gasolina	FWD	1398	74	100	06.10-03.17	*
1.4 (75) (B 14 XER)		Gasolina	FWD	1398	74	100	06.10-03.17	*
1.4 LPG (75) (A 14 NEL)		Gasol./Gas (LPG)	FWD	1364	88	120	06.11-03.17	*
1.4 LPG (75) (B 14 NEL)		Gasol./Gas (LPG)	FWD	1364	88	120	06.11-03.17	*
1.3 CDTi (75) (A 13 DTC)		Diesel	FWD	1248	55	75	06.10-10.13	*
1.3 CDTi (75) (A 13 DTE)		Diesel	FWD	1248	70	95	06.10-11.14	*
1.7 CDTi (75) (A 17 DT)		Diesel	FWD	1686	74	100	06.10-01.17	*
1.7 CDTi (75) (A 17 DTC)		Diesel	FWD	1686	81	110	06.10-06.15	*
1.7 CDTi (75) (A 17 DTI)		Diesel	FWD	1686	81	110	06.10-06.15	*
MERIVA B VAN (S10) 06.10-03.17					Furgoneta/MPV (Mini MPV-M1 Segment)			
1.4 ECOTEC (75)		Gasolina	FWD	1398	74	101	01.13-03.17	*
1.3 CDTi (75)		Diesel	FWD	1248	70	95	01.13-11.14	*
1.7 CDTi (75)		Diesel	FWD	1686	74	101	01.13-01.17	*
1.7 CDTi (75)		Diesel	FWD	1686	81	110	01.13-10.13	*
ZAFIRA A (T98) 04.99-06.06					MPV (Compact MPV-M1 Segment)			
1.6		Gasolina	FWD	1598	70	95	09.02-06.05	*
1.6 16V (F75) (X 16 XEL)		Gasolina	FWD	1598	74	101	04.99-06.05	*
1.6 16V (F75) (Z 16 XE)		Gasolina	FWD	1598	74	101	04.99-06.05	*
1.6 (F75) (Z 16 XE)		Gasolina	FWD	1598	76	103	10.03-06.05	*

LISTA DE APLICACIONES - BUYERS GUIDE

1.8		Gasolina	FWD	1796	81	110	02.03-06.05	*	
1.8 16V (F75) (X 18 XE1)		Gasolina	FWD	1796	85	116	04.99-09.00	*	
1.8 16V (F75) (Z 18 XE)		Gasolina	FWD	1796	92	125	09.00-06.05	*	
2.2 16V (F75) (Z 22 SE)		Gasolina	FWD	2198	108	147	09.00-06.05	*	
1.6 LPG (F75) (X 16 XEL)		Gasol./Gas (LPG)	FWD	1598	74	101	04.99-06.05	*	
1.6 LPG (F75) (Z 16 XE)		Gasol./Gas (LPG)	FWD	1598	74	101	04.99-06.05	*	
1.6 LPG (F75) (Z 16 XEP)		Gasol./Gas (LPG)	FWD	1598	76	103	10.03-06.05	*	
1.6 CNG (F75) (Z 16 YNG)		Gasol./Gas (CNG)	FWD	1598	71	97	09.01-06.05	*	
2.0 DI 16V (F75) (X 20 DTL)		Diesel	FWD	1995	60	82	07.99-06.05	*	
2.0 DI 16V (F75) (Y 20 DTL)		Diesel	FWD	1995	60	82	07.99-06.05	*	
2.0 DI (F75)		Diesel	FWD	1995	63	86	07.99-06.00	*	
2.0 DTI 16V (F75) (Y 20 DTH)		Diesel	FWD	1995	74	101	09.00-06.05	*	
2.2 DTI 16V (F75) (Y 22 DTR)		Diesel	FWD	2172	86	117	01.02-06.05	*	
2.2 DTI 16V (F75) (Y 22 DTR)		Diesel	FWD	2172	92	125	01.02-06.05	*	
ZAFIRA B (A05) 07.05-							Furgoneta/MPV (LCVs-N1 Segment)		
1.8 VAN (M75) (A 18 XER)		Gasolina	FWD	1796	103	140	07.05-04.15	*	
1.8 VAN (M75) (Z 18 XER)		Gasolina	FWD	1796	103	140	07.05-04.15	*	
ZAFIRA / ZAFIRA FAMILY B (A05) 07.05-							MPV (Compact MPV-M1 Segment)		
1.6 (M75) (Z 16 XE1)		Gasolina	FWD	1598	77	105	07.05-09.12	*	
1.6 (M75) (Z 16 XEP)		Gasolina	FWD	1598	77	105	07.05-09.12	*	
1.6 (M75) (A 16 XER)		Gasolina	FWD	1598	85	115	01.08-04.15	*	
1.6 (M75) (Z 16 XER)		Gasolina	FWD	1598	85	115	01.08-04.15	*	
1.8 (M75) (A 18 XER)		Gasolina	FWD	1796	103	140	07.05-04.15	*	
1.8 (M75) (Z 18 XER)		Gasolina	FWD	1796	103	140	07.05-04.15	*	
1.8 LPG (M75) (Z 18 XER)		Gasol./Gas (LPG)	FWD	1796	103	140	07.09-04.15	*	
1.6 CNG (M75) (Z 16 YNG)		Gasol./Gas (CNG)	FWD	1598	69	94	07.05-04.15	*	
1.6 FlexFuel (M75) (Z 16 XER)		Gasol./Etanol	FWD	1598	85	116	08.08-12.12	*	
VAUXHALL									
ASTRA Mk IV (G) (T98) 02.98-05.05							[CAMBIADO]:Break (Compact car-C Segment)		
1.4 16V (X 14 XE)		Gasolina	FWD	1389	66	90	02.98-05.05	*	
1.4 16V (Z 14 XE)		Gasolina	FWD	1389	66	90	02.98-05.05	*	
1.6 (X 16 SZR)		Gasolina	FWD	1598	55	75	03.98-04.04	*	
1.6 (Z 16 SE)		Gasolina	FWD	1598	62	84	03.98-04.04	*	
1.6 16V (X 16 XEL)		Gasolina	FWD	1598	74	101	03.98-04.04	*	
1.6 16V (Z 16 XE)		Gasolina	FWD	1598	74	101	03.98-04.04	*	
1.6 (Z 16 XEP)		Gasolina	FWD	1598	76	103	12.02-05.05	*	
1.8 16V (X 18 XE1)		Gasolina	FWD	1796	85	116	02.98-08.00	*	
1.8 16V (Z 18 XE)		Gasolina	FWD	1796	92	125	09.00-05.05	*	
2.0 16V		Gasolina	FWD	1998	100	136	02.98-05.05	*	
2.2 16V (Z 22 SE)		Gasolina	FWD	2198	108	147	03.01-05.05	*	
1.6 Dualfuel (Z 16 SE)		Gasol./Gas (LPG)	FWD	1598	63	85	03.98-04.04	*	
1.8 16V Dualfuel (Z 18 XE)		Gasol./Gas (LPG)	FWD	1796	87	118	09.02-05.05	*	
1.8 16V Dualfuel (Z 18 XE)		Gasol./Gas (LPG)	FWD	1796	92	125	07.02-12.03	*	
2.0 DI (X 20 DTL)		Diesel	FWD	1995	60	82	03.98-04.04	*	

LISTA DE APLICACIONES - BUYERS GUIDE

2.0 DI (Y 20 DTL)		Diesel	FWD	1995	60	82	03.98-04.04	*	
2.0 DTI 16V (Y 20 DTH)		Diesel	FWD	1995	74	101	03.98-04.04	*	
ASTRA Mk IV (G) (T98) 02.98-05.05							[CAMBIADO]:Fastback (Compact car-C Segment)		
1.6 16V (F08, F48) (X 16 XEL)		Gasolina	FWD	1598	74	101	02.98-05.05	*	
1.6 16V (F08, F48) (Z 16 XE)		Gasolina	FWD	1598	74	101	02.98-05.05	*	
1.6 (F08, F48) (Z 16 XEP)		Gasolina	FWD	1598	76	103	12.02-05.05	*	
1.8 16V (F08, F48) (X 18 XE1)		Gasolina	FWD	1796	85	116	02.98-09.00	*	
1.8 16V (F08, F48) (Z 18 XE)		Gasolina	FWD	1796	92	125	09.00-05.05	*	
2.0 16V (F08) (X 20 XEV)		Gasolina	FWD	1998	100	136	02.98-05.05	*	
2.0 (F08, F48)		Gasolina	FWD	1998	118	160	10.99-08.00	*	
2.0 SRI Turbo (F08) (Z 20 LET)		Gasolina	FWD	1998	141	192	11.01-05.05	*	
2.2 16V (F08, F48) (Z 22 SE)		Gasolina	FWD	2198	108	147	03.01-05.05	*	
1.8 16V Dualfuel (F08, F48) (Z 18 XE)		Gasol./Gas (LPG)	FWD	1796	87	118	09.02-05.05	*	
1.8 16V Dualfuel (F08, F48) (Z 18 XE)		Gasol./Gas (LPG)	FWD	1796	92	125	07.02-12.03	*	
2.0 DI (F48) (X 20 DTL)		Diesel	FWD	1995	60	82	02.98-05.05	*	
2.0 DI (F48) (Y 20 DTL)		Diesel	FWD	1995	60	82	02.98-05.05	*	
2.0 DTI 16V (F48) (Y 20 DTH)		Diesel	FWD	1995	74	101	08.99-05.05	*	
ASTRA Mk IV (G) (T98) 03.01-10.05							Cabrio (Compact car-C Segment)		
1.6 16V (Z 16 XE)		Gasolina	FWD	1598	74	101	03.01-10.05	*	
1.8 16V (Z 18 XE)		Gasolina	FWD	1796	92	125	03.01-10.05	*	
2.0 Turbo (Z 20 LET)		Gasolina	FWD	1998	141	192	03.02-10.05	*	
2.0 (Z 20 LET)		Gasolina	FWD	1998	147	200	09.02-10.05	*	
2.2 16V (Z 22 SE)		Gasolina	FWD	2198	108	147	03.01-10.05	*	
ASTRA Mk IV (G) (T98) 03.00-08.05							Coupé (Compact car-C Segment)		
1.6 16V (Z 16 XEP)		Gasolina	FWD	1598	76	103	03.00-08.05	*	
1.8 16V (X 18 XE1)		Gasolina	FWD	1796	85	115	03.00-08.05	*	
1.8 16V (Z 18 XE)		Gasolina	FWD	1796	92	125	09.00-08.05	*	
2.0 16V Turbo (Z 20 LET)		Gasolina	FWD	1998	140	190	09.00-08.05	*	
2.0		Gasolina	FWD	1998	147	199	08.02-05.05	*	
2.2 16V (Z 22 SE)		Gasolina	FWD	2198	108	147	03.00-08.05	*	
1.8 16V Dualfuel (Z 18 XE)		Gasol./Gas (LPG)	FWD	1796	87	118	09.02-08.05	*	
1.8 16V Dualfuel (Z 18 XE)		Gasol./Gas (LPG)	FWD	1796	92	125	07.02-08.04	*	
ASTRA Mk IV (G) (T98) 02.98-05.05							Sedán (Compact car-C Segment)		
1.6 16V (X 16 XEL)		Gasolina	FWD	1598	74	101	09.98-05.05	*	
1.6 16V (Z 16 XE)		Gasolina	FWD	1598	74	101	09.98-05.05	*	
1.8 16V (X 18 XE1)		Gasolina	FWD	1796	85	116	02.98-07.04	*	
1.8 16V (Z 18 XE)		Gasolina	FWD	1796	92	125	02.98-07.04	*	
2.0 16V (X 20 XEV)		Gasolina	FWD	1998	100	136	09.98-05.05	*	
2.2 16V		Gasolina	RWD	2198	108	147	03.01-05.05	*	
1.8 16V Dualfuel (Z 18 XE)		Gasol./Gas (LPG)	FWD	1796	87	118	02.98-07.04	*	
1.8 16V Dualfuel		Gasol./Gas (LPG)	FWD	1796	92	125	07.02-12.03	*	
2.0 DI (X 20 DTL)		Diesel	FWD	1995	60	82	02.98-07.04	*	
2.0 DI (Y 20 DTL)		Diesel	FWD	1995	60	82	02.98-07.04	*	
2.0 DTI 16V (Y 20 DTH)		Diesel	FWD	1995	74	101	02.98-07.04	*	
ASTRA Mk V (H) (A04) 08.04-10.12							[CAMBIADO]:Break (Compact car-C Segment)		
1.6 (L35) (A 16 LET)		Gasolina	FWD	1598	132	180	08.04-03.09	*	

LISTA DE APLICACIONES - BUYERS GUIDE

1.6 (L35) (Z 16 LET)		Gasolina	FWD	1598	132	180	08.04-03.09	*	
1.8 (L35) (Z 18 XE)		Gasolina	FWD	1796	92	125	10.04-03.09	*	
1.8 (L35) (A 18 XER)		Gasolina	FWD	1796	103	140	12.05-10.10	*	
1.8 (L35) (Z 18 XER)		Gasolina	FWD	1796	103	140	12.05-10.10	*	
1.3 CDTI (L35) (Z 13 DTH)		Diesel	FWD	1248	66	90	08.04-03.09	*	
1.7 CDTI (L35) (Z 17 DTH)		Diesel	FWD	1686	74	100	08.04-03.09	*	
1.7 TD		Diesel	RWD	1686	79	108	08.04-03.09	*	
1.7 CDTI (L35) (A 17 DTJ)		Diesel	FWD	1686	81	110	08.04-10.12	*	
1.7 CDTI (L35) (Z 17 DTJ)		Diesel	FWD	1686	81	110	08.04-10.12	*	
ASTRA Mk V (H) (A04) 01.04-03.11							[CAMBIADO]:Fastback (Compact car-C Segment)		
1.8 (L48) (Z 18 XE)		Gasolina	FWD	1796	92	125	01.04-05.09	*	
1.8 (L48) (A 18 XER)		Gasolina	FWD	1796	103	140	01.04-05.09	*	
1.8 (L48) (Z 18 XER)		Gasolina	FWD	1796	103	140	01.04-05.09	*	
1.3 CDTI (L48) (Z 13 DTH)		Diesel	FWD	1248	66	90	01.04-05.09	*	
1.7 CDTI (L48) (Z 17 DTL)		Diesel	FWD	1686	59	80	01.04-05.09	*	
1.7 CDTI (L48) (Z 17 DTH)		Diesel	FWD	1686	74	100	01.04-05.09	*	
1.7 TD		Diesel	RWD	1686	79	108	01.04-05.09	*	
1.7 CDTI (L48) (A 17 DTJ)		Diesel	FWD	1686	81	110	01.04-03.11	*	
1.7 CDTI (L48) (Z 17 DTJ)		Diesel	FWD	1686	81	110	01.04-03.11	*	
ASTRA Mk V (H) Sport Hatch (A04) 02.05-11.10							[CAMBIADO]:Fastback (Compact car-C Segment)		
1.4 i 16V (L08) (Z 14 XEP)		Gasolina	FWD	1364	66	90	03.05-11.10	*	
1.6 i 16V (L08) (A 16 XER)		Gasolina	FWD	1598	85	116	12.06-11.10	*	
1.6 i 16V (L08) (Z 16 XER)		Gasolina	FWD	1598	85	116	12.06-11.10	*	
1.8 (L08) (Z 18 XE)		Gasolina	FWD	1796	92	125	02.05-11.10	*	
1.8 i 16V (L08) (A 18 XER)		Gasolina	FWD	1796	103	140	03.07-11.10	*	
1.8 i 16V (L08) (Z 18 XER)		Gasolina	FWD	1796	103	140	03.07-11.10	*	
1.3 CDTI (L08) (Z 13 DTH)		Diesel	FWD	1248	66	90	04.05-11.10	*	
1.7 CDTi (L08) (Z 17 DTH)		Diesel	FWD	1686	74	100	02.05-11.10	*	
1.7 CDTi (L08) (A 17 DTJ)		Diesel	FWD	1686	81	110	02.07-11.09	*	
1.7 CDTi (L08) (Z 17 DTJ)		Diesel	FWD	1686	81	110	02.07-11.09	*	
ASTRA Mk V (H) TwinTop (A04) 09.05-08.11							Cabrío (Compact car-C Segment)		
1.6 (L67) (Z 16 XEP)		Gasolina	FWD	1598	77	105	09.05-11.10	*	
1.6 i 16V (L67) (A 16 XER)		Gasolina	FWD	1598	85	116	10.06-08.11	*	
1.6 i 16V (L67) (Z 16 XER)		Gasolina	FWD	1598	85	116	10.06-08.11	*	
1.6		Gasolina	FWD	1598	132	179	10.06-11.10	*	
1.8 (L67) (A 18 XER)		Gasolina	FWD	1796	103	140	05.08-11.10	*	
1.8 (L67) (Z 18 XER)		Gasolina	FWD	1796	103	140	05.08-11.10	*	
ASTRAVAN Mk IV (G) (T98) 01.93-08.06							[CAMBIADO]:Furgón/Break (Compact car-C Segment)		
1.6 Dualfuel 16V (Z 16 XEP)		Gasol./Gas (LPG)	FWD	1598	77	105	10.04-12.05	*	
1.7 CDTi (Z 17 DTL)		Diesel	FWD	1686	59	80	07.03-08.06	*	
2.0 DI (X 20 DTL)		Diesel	FWD	1995	60	82	08.98-08.06	*	
2.0 DI (Y 20 DTL)		Diesel	FWD	1995	60	82	08.98-08.06	*	
2.0 DTI (Y 20 DTH)		Diesel	FWD	1995	74	100	04.04-08.06	*	
ASTRAVAN Mk V (H) (A04) 03.05-							[CAMBIADO]:Furgón/Break (Compact car-C Segment)		
1.4 i (Z 14 XEP)		Gasolina	FWD	1364	66	90	03.05-	*	
1.6 (Z 16 XE1)		Gasolina	FWD	1598	76	103	03.05-	*	
1.6 (Z 16 XEP)		Gasolina	FWD	1598	76	103	03.05-	*	
1.3 CDTi (Z 13 DTH)		Diesel	FWD	1248	66	90	08.05-	*	

LISTA DE APLICACIONES - BUYERS GUIDE

1.7 CDTi (Z 17 DTH)		Diesel	FWD	1686	74	101	03.05-11.11	*
1.7 CDTi (A 17 DTJ)		Diesel	FWD	1686	81	110	06.11-12.13	*
1.7 CDTi (Z 17 DTJ)		Diesel	FWD	1686	81	110	06.11-12.13	*
COMBO Mk II (C) (F25) 09.01-02.12					Furgoneta/MPV (LCVs-N1 Segment)			
1.7 CDTi 16V (Z 17 DTH)		Diesel	FWD	1686	74	101	12.04-11.11	*
COMBO TOUR Mk II (C) (F25) 09.01-02.12					MPV (Large MPV-M1 Segment)			
1.7 CDTi 16V (Z 17 DTH)		Diesel	FWD	1686	74	101	12.04-09.10	*
MERIVA Mk I (A) (X03) 01.03-06.10					MPV (Mini MPV-M1 Segment)			
1.3 CDTi (Y 13 DT)		Diesel	FWD	1248	51	69	04.05-06.10	*
1.3 CDTi (Z 13 DT)		Diesel	FWD	1248	51	69	04.05-06.10	*
1.7 DTI (Y 17 DT)		Diesel	FWD	1686	55	75	06.03-06.10	*
1.7 CDTi (Z 17 DTH)		Diesel	FWD	1686	74	100	09.03-06.08	*
1.7 CDTi		Diesel	RWD	1686	92	125	08.06-06.10	*
MERIVA Mk II (B) (S10) 06.10-					MPV (Mini MPV-M1 Segment)			
1.4 (A 14 NEL)		Gasolina	FWD	1364	88	120	06.10-10.13	*
1.4 (B 14 NEL)		Gasolina	FWD	1364	88	120	06.10-10.13	*
1.4 (A 14 XER)		Gasolina	FWD	1398	74	101	06.10-03.17	*
1.4 (B 14 XER)		Gasolina	FWD	1398	74	101	06.10-03.17	*
1.4 LPG (A 14 NEL)		Gasol./Gas (LPG)	FWD	1364	88	120	06.11-03.17	*
1.3 CDTi (A 13 DTC)		Diesel	FWD	1248	55	75	06.10-10.13	*
1.3 CDTi (A 13 DTE)		Diesel	FWD	1248	70	95	06.10-11.14	*
1.7 CDTi (A 17 DT)		Diesel	FWD	1686	74	101	06.10-01.17	*
1.7 CDTi (A 17 DTC)		Diesel	FWD	1686	81	110	06.10-06.15	*
1.7 CDTi (A 17 DTI)		Diesel	FWD	1686	81	110	06.10-06.15	*
1.7 CDTi (A 17 DTS)		Diesel	FWD	1686	96	131	06.10-10.13	*
ZAFIRA Mk I (A) (T98) 11.98-08.05					MPV (Compact MPV-M1 Segment)			
1.6 16V (X 16 XEL)		Gasolina	FWD	1598	74	101	04.99-08.05	*
1.6 16V (Z 16 XE)		Gasolina	FWD	1598	74	101	04.99-08.05	*
1.8 16V (X 18 XE1)		Gasolina	FWD	1796	85	116	05.99-08.00	*
1.8 16V (Z 18 XE)		Gasolina	FWD	1796	92	125	09.00-08.05	*
2.2 16V (Z 22 SE)		Gasolina	FWD	2198	108	147	11.98-08.04	*
1.6 Dualfuel (X 16 XEL)		Gasol./Gas (LPG)	FWD	1598	74	101	11.98-08.05	*
1.8 Dualfuel (Z 18 XE)		Gasol./Gas (LPG)	FWD	1796	92	125	09.00-08.05	*
1.6 CNG (Z 16 YNG)		Gasol./Gas (CNG)	FWD	1598	71	97	09.01-06.05	*
2.0 DI 16V (X 20 DTL)		Diesel	FWD	1995	60	82	10.99-08.05	*
2.0 DTI 16V (Y 20 DTH)		Diesel	FWD	1995	74	101	04.99-08.05	*
2.2 D		Diesel	FWD	2172	92	125	06.01-06.05	*
ZAFIRA Mk II (B) (A05) 04.05-11.14					MPV (Compact MPV-M1 Segment)			
1.8 (A 18 XEL)		Gasolina	FWD	1796	88	120	04.13-11.14	*
1.8 (A 18 XER)		Gasolina	FWD	1796	103	140	04.05-11.14	*
1.8 (Z 18 XER)		Gasolina	FWD	1796	103	140	04.05-11.14	*